



✉ info@naygn.org
📍 PO BOX 32642
Charlotte, NC 28232-2642
🌐 NAYGN.ORG

2027 EXHIBITOR & CONFERENCE PROSPECTUS

What is NAYGN?

North American Young Generation in Nuclear (NAYGN) is a 501(c)(6) non-profit, all volunteer professional organization committed to our mission of **“Developing Leaders to Energize the Future of Nuclear”**. For over 25 years, NAYGN has made meaningful and lasting impact on the nuclear industry and the communities it serves. Our achievements are made possible through the generous support of our sponsors, which enables us to fund high-impact initiatives and sustain organizational excellence.

In 2025, our 120+ chapters contributed over **125,000 volunteer hours** across nuclear organizations, schools, local communities, and institutions. Through advocacy, outreach, and leadership development, our members champion the benefits of nuclear energy while preparing to lead the industry forward. Our diverse membership spans students, early-career professionals, supervisors, directors, and executives, all united by a shared commitment to growth and innovation.

To learn more, visit us at naygn.org.

Partner with us in 2027 to help energize the future of nuclear – your support will drive meaningful lasting, impact.

About the Conference

NAYGN is excited to host the **2027 Continental Conference**, from **Sunday, June 13 to Wednesday, June 16** in Toronto, Canada at the **Marriott Downtown at CF Toronto Eaton Centre**.

This dynamic event is tailored for nuclear professionals and advocates who are seeking to grow through professional development, soft skills training, technical sessions, and meaningful networking opportunities.

Attendees will also have access to our Exhibition Hall, open throughout the conference during session breaks and meals. A dedicated networking event will further enhance collaboration and engagement. Exhibitor booth is limited and will be available on a first-come, first-served basis.



Why Exhibit?

Exhibiting at NAYGN's 2027 Continental Conference offers a unique opportunity to connect directly with the next generation of nuclear professionals, nuclear advocates, and industry leaders. Here's why your organization should exhibit:

Direct Access to Emerging Talent

Engage with the next generation of nuclear professionals—students, young engineers, and early career leaders—who are shaping the future of the industry.

Build Brand Awareness

Showcase your organization's mission, values, and innovations to a highly targeted audience passionate about nuclear energy and technology.

Share Innovations

Demonstrate your latest technologies, products, or services to a receptive audience of peers, partners, and future collaborators.

Network with Industry Leaders

Meet and collaborate with over 300 professionals and industry leaders from around the world. Build relationships with key stakeholders, potential partners, and thought leaders in the nuclear industry.

Support the Nuclear Community

Show your commitment to the growth and sustainability of the nuclear industry by supporting its rising professionals and advocates.

Gain Market Insights

Learn about emerging trends, challenges, and opportunities in the nuclear field through direct conversations and feedback from attendees.

For questions, email conference@naygn.org

Exhibitor Package & Details

Exhibitor Booth Pricing (USD): \$7,000

Exhibitor Booth Details

Exhibitor Booth Includes:

- Booth Space (10'x10')
- One (1) 6' Table
- Two (2) Chairs
- One (1) Full Conference Badge
- One (1) Exhibition Hall Only Badge
- Complimentary Internet

Full Conference Registration Badge Includes:

- Admission to Conference Sessions
- Admission to Conference Networking Events
- Breakfast, Lunches and Breaks

Exhibition Hall Only Badge

- Limited Access – Exhibition Hall Only
- Breakfast, Lunches and Breaks

Available Upgrades (USD)

EXHIBITOR OPTIONS	Regular
Upgrade from Exhibition Hall Only Badge to Full Conference Registration	\$400
Additional Booth Representative Exhibition Hall Only Badge	\$400
Additional Booth Representative Full Conference Registration	\$800
Sunday Networking Event Additional Ticket	\$100
Monday Networking Event Additional Ticket	\$150

*Please note all costs above are in USD.

Setup and Breakdown

Please note the schedule is subject to change and all times are in Eastern Time (ET).

Exhibitor Move-In Sunday June 13th, after 12:00 PM

Exhibitor Move-Out Wednesday June 16th, after 7:00 AM



Exhibition Hall Layout

Grand Ballroom Foyer

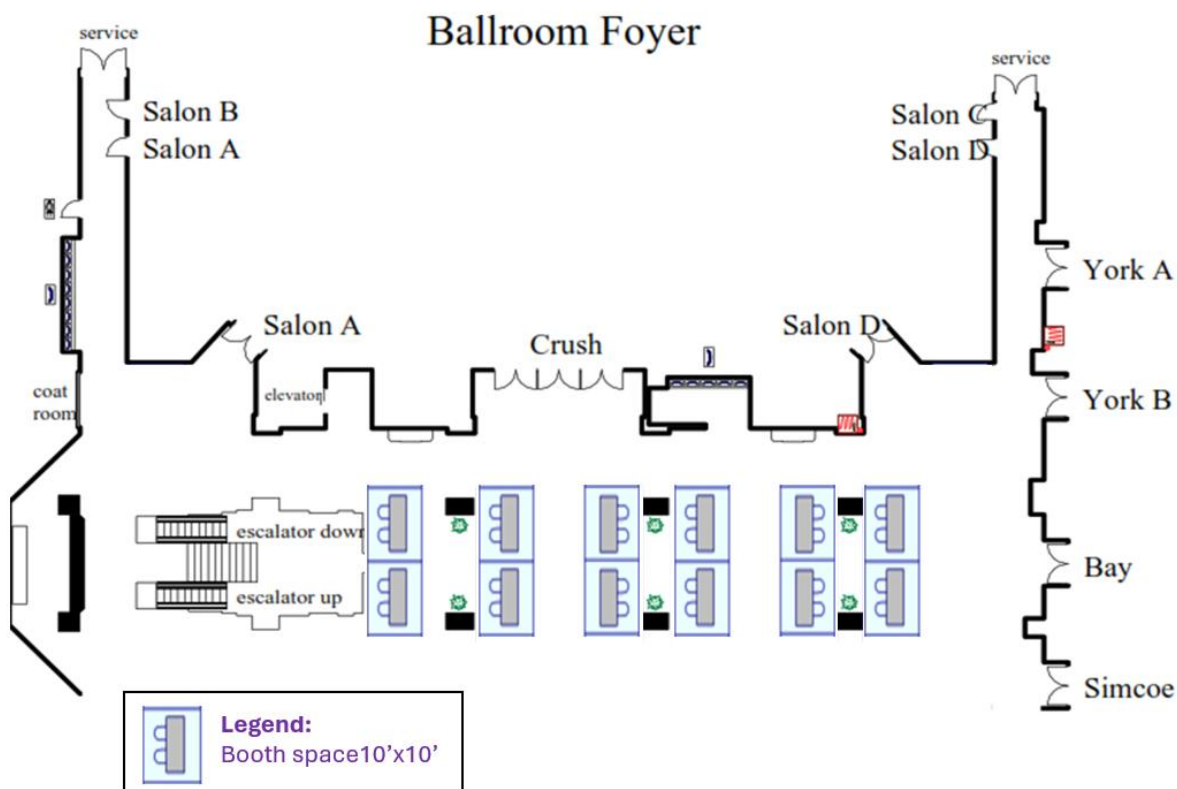

Conference Sponsorship Opportunities

Showcase your company's visibility, engagement, and dedication to the future of nuclear by sponsoring key opportunities at the NAYGN 2027 Continental Conference.

This Conference Sponsorship Opportunity is distinct from the NAYGN Organizational Sponsorship, which supports the organization's year-round initiatives.

Breakfast

\$3,500 USD (2 available)

- Branded visibility at food and beverage stations
- Recognition on conference website
- Custom push notification (approval required)
- Acknowledgement during conference
- Food and beverage selection

Sunday Welcome Reception

\$5,000 USD (3 available)

- Branded visibility at food and beverage stations
- Recognition on conference website
- Recognition on push notification
- Acknowledgement during conference
- *Sponsor all three – Food and beverage selection, custom push notification, and custom vertical banner)*

Lunch

\$4,000 USD (2 available)

- Branded visibility at food and beverage stations
- Recognition on conference website
- Custom push notification (approval required)
- Acknowledgement during conference
- Food and beverage selection

Monday Evening Networking Event

\$8,000 USD (3 available)

- Branded visibility at food and beverage stations
- Recognition on conference website
- Recognition on push notification
- Acknowledgement during conference
- *Sponsor all three – Food and beverage selection, custom push notification, and custom vertical banner)*

Break

\$1,500 USD (2 available)

- Branded visibility at food and beverage stations
- Recognition on conference website
- Custom push notification (approval required)
- Acknowledgement during conference
- Food and beverage selection

NAYGN does not guarantee specific levels of attendance at the conference sponsorship activities. Sponsors shall not be entitled to any refund bas on attendance

Exhibitor and Conference Sponsorship Agreement

Please complete the following [Exhibitor and Conference Sponsorship Agreement Form](#) online to reserve your place for the 2027 NAYGN Continental Conference.

Cancellation Policy

All cancellation requests must be submitted to conference@naygn.org

Submission of the agreement form constitutes a binding agreement between the exhibitor/sponsor and NAYGN. In the event of cancellation for any reason, the exhibitor/sponsor remains fully responsible for the total agreement amount, regardless of the timing of cancellation or any agreed-upon payment schedule.

This policy ensures the integrity of event planning and resource allocation. NAYGN reserves the right to enforce this policy in accordance with applicable laws.

Terms & Conditions

1. Agreement Activation

Exhibitor benefits cannot be fulfilled until this agreement is electronically signed via the official online form and full payment is received by NAYGN.

2. Binding Contract

Submission of this form constitutes a legally binding agreement between the Exhibitor and NAYGN.

3. Indemnification

Each party agrees to indemnify and hold harmless the other party and its employees, members, landlord, successors, and assigns, from any claims, liabilities, losses, damages, and expenses asserted against the other party and arising out of the indemnifying party's negligence, willful misconduct, and negligent performance of, or failure to perform, any of its duties or obligations under this Agreement. The provisions of this indemnification are solely for the benefit of the parties hereto and not intended to create or grant any rights, contractual or otherwise, to another person or entity.

4. No Endorsement

Participation in the event does not imply endorsement of any product, service, or organization by NAYGN.

5. Intellectual Property

NAYGN will be held harmless for any trademark, tradename, copyright, or patent infringement on any printed materials belonging to or distributed by any exhibitor or conference sponsor. Exhibitors are solely responsible for ensuring that all materials used or distributed by them comply with applicable trademarks, copyright, and patent laws.

6. Subletting Prohibited

Booth space may not be shared transferred, or sublet without prior written approval from NAYGN.

7. Compliance with Rules

The Exhibitor agrees to abide by all regulations and rules adopted by NAYGN in the best interests of the Conference and agrees that NAYGN shall have the final decision in adopting any rule or regulation deemed necessary prior to, during and after the Conference.

8. Liability for Damages

Exhibitor will be liable for any loss or damages whatsoever suffered by NAYGN as a result of any loss or damages whatsoever occurring to or suffered by any person or company, including without limiting the generality of the foregoing, Exhibitor, other Exhibitors, NAYGN, the owner of the building and their respective agents, servants and employees and members of the public attending the Conference, either on the said space or elsewhere if said loss or damages arose from or were in any way connected with Exhibitor's occupancy of said space.

9. Booth Assignment

NAYGN reserves the right to alter or change the space assigned to the Exhibitor at its discretion.

10. Conduct and Presentation

NAYGN reserves the right at any time to alter or remove exhibits or any part thereof, including printed materials, product, signs, lights, or sound, and to expel Exhibitors or their personnel if, in NAYGN's opinion, their conduct or presentation is deemed inappropriate, disruptive, or offensive to attendees or other exhibitors.

11. Booth Use

Exhibitor agrees to confine their presentation within their assigned booth space only and adhere to height and display restrictions.

12. Loss or Damage

NAYGN assumes no responsibility for any loss or damage to exhibitor property before, during, or after the event.

13. Insurance

The Exhibitor is responsible for securing and maintaining appropriate insurance coverage for their participation in the Conference.

14. Move-Out Requirements

The Exhibitor agrees that no display may be dismantled during the entire run of the Conference and must remain intact until the closing hour of the last day of the Conference. The Exhibitor also agrees to remove their exhibit, equipment, and appurtenances from the Conference building by the final move-out time limit, or in the event of failure to do so, the Exhibitor agrees to pay for such additional costs as they may be incurred.

15. Networking Sponsorships

NAYGN does not guarantee attendance levels at networking events. No refunds will be issued based on turnout.

16. Force Majeure

NAYGN reserves the right at its sole discretion to change the date or dates upon which the Conference is to be held and shall not be liable in damages or otherwise by reason of any such change. In addition, NAYGN shall not be liable in damages or otherwise for failure to carry out the terms of this Agreement in whole or in part where, caused directly or indirectly by, or in consequence of, fire, storm, flood, war, rebellion, insurrection, riot, civil commotion, strike or by any cause whatever beyond the control of NAYGN whether similar or dissimilar from the causes enumerated herein. In the event that the exhibit space to be used by the Exhibitor should in any way be rendered unusable, the Exhibitor shall pay for such space only for the period during which it was or could have been used as determined within the sole discretion of NAYGN. A refund of all monies paid by the Exhibitor to NAYGN will be made by NAYGN in the event that the Conference is fully cancelled.

17. Contract Termination

NAYGN reserves the right to cancel this contract and to withhold possession of exhibit space if the Exhibitor fails to perform any material condition of this contract or refuses to abide by the Conference rules and regulations, in which case the Exhibitor shall forfeit as liquidation damages all space rental payments made by them and any further occupancy of such space.

18. Labor and Union Compliance

The Exhibitor agrees to observe all union contracts and labor relations in force, agreements between NAYGN, official contractors serving companies and the building in which the Conference will take place and according to the labor laws of the jurisdiction in which the building is located.